

# BROCHURE

## Variable Speed Drives & Accessories



NIETZ

### » WHO WE ARE

NIETZ is one Leading Manufacturer of industrial automation products, with more than millions units sold worldwide, established 2005 Shanghai, China. We are committed to building long-lasting and successful business relations with our partners, has gained good reputation and deep influence.

We aim to provide the best quality, unmatched reliability and low price in our services and our products. We aim to reduce your costs, streamline manufacturing, to improve productivity.

The products of NIETZ are Variable Frequency Inverters, AC Servo System, Soft Starter, Planetary Gearboxes and Complete Device, The products NIETZ are technological advanced products and it has quite wide product range and already used widely in various applications such as textile machine, air compressor, hoist, packing machine, printing machine, electronic machine and other industries, which exported to over 40 countries and regions such as Europe, South America, Southeast Asia, Middle East and so on.

NIETZ always aims to be the professional driving solution provider and your mutual-benefit partner. «



Factory View



Reception



Production Workshop



SMT Lines



Assembly Workshop



Testing Lines

## CONTENTS

### Variable Speed Drives

- 02 NL1000
- 03 AT20
- 04 NZ2000
- 05 NZ8000
- 06 NZS
- 07 PDS-7
- 08 WP9
- 09 APV
- 10 CV20
- 11 ESD / ESD2
- 12 AMD
- 13 AT10

# NL1000

Micro & Economic

- Small Dimension, Low Cost
- Terminals Uncovered, Easy to Use and Wiring
- DIN-Rail Mounting and Wall Mounting
- Support MODBUS via RS485
- V/F Control; Built-in PID Control
- Frequency Range 0.1...999.9Hz



Item		Specifications	
Power Supply	Rated Voltage	220 VAC, 50/60Hz, 1 Phase Input and 3 Phase Output 220 VAC, 50/60Hz, 1 Phase Input and 1 Phase Output 220 VAC, 50/60Hz, 3 Phase Input and 3 Phase Output 380 VAC, 50/60Hz, 3 Phase Input and 3 Phase Output	
	Voltage Range	220 VAC	170-240 VAC
Output	Voltage Range	220 VAC	0-240 VAC
	Frequency Range	380 VAC	0-380 VAC
Control Mode		V/F Control, Space Vector Control	
Indication		Operating status/Alarm definition/interactive guidance: eg, frequency setting, the output frequency/ current, DC bus voltage, the temperature and so on.	
Control Specification	Output Frequency Range	0.10-999.90 Hz	
	Frequency Setting Resolution	Digital Input	0.1 Hz
	Output Frequency Accuracy	Analog Input	0.1% of Max. Output Frequency
	V/F Control	Setting V/F Curve to Satisfy Various Load Requirements	
	Torque Control	Auto Increase	Auto raise Torque by Loading Condition
		Manual Increase	Enable to Set 0.1-20.0% of Raising Torque
	Multi-Functional Output Terminal	One Multi-Fuction Output Terminal for Displaying of Running, Zero Speed, Counter, External Abnornity, Program Operation and Other Information and UP / DOWN Fuction and Emergency Stop and Other Functions.	
	Multi-Functional Input Terminal	Four Multi-Fuction Input Terminals, Realizing Functions Including 15 Sections Speed Control, Program Running, 4 Section Acceleration / Deceleration Speed Switch, Warnings.	
Accel/Decel Time	0-999.9s Acceleration/Deceleration Time can be Set Individually		
Others Functions	Frequency Setting	Analog input	0 to 10V, 0to 20mA can be Selected.
		Digital Input	Input Using the Setting Dial of the Operation Panel or RS485 or UP/DOWN.
		Note	AVI Terminals can be Used to Select an Analog Voltage Input (0-10V) and Analog Current Input (4-20mA) through the Switch J2.
	Multi-Speed	4 Multi-Fuction Input Terminals, 15 sections Speed can be Set	
	Automatic Voltage Regulation	Automatic Voltage Regulation Function can be Selected	
Counter	Built-in 2 Group of Counters		
Protection Function	Overload	150%, 60 s (Constant Torque)	
	Over Voltage	Over Voltage Protection can be Selt.	
	Under Voltage	Under Voltage Protection can be Set.	
	Other Protections	Output Short Circuit, Over Current and Parameter Lock and so on.	
Environment Installation	Ambient Temperature	-10 to 40°C (Non-Condensing)	
	Ambient Humidity	Max. 95% (No-Condensing)	
	Altitude	Lower Than 1000m	
	Vibration	Max. 0.5G	
	Cooling Mode	Forced Air Cooling.	
	Protection Class	IP20	
	Installation Mode	Wall-Mounted or Standard 35mm Rail Mounting (Below 5.5kW)	

# AT20

General Purpose, Compact

- Various Control Version, V/F, Sensorless Vector and Closed Loop Vector Control
- Built-in braking unit up to 450kW (optional)
- Support MODBUS RS485, ProfiNet is Selectable
- Digital and analogue I/O optional cards
- Support different PG cards, including resolver
- Suitable AC Induction Motor, Permanent Magnet Synchronous Motor is selectable

Remove keypad



Item		Specifications
Basic Function	Control Mode	V/F Control Sensorless Flux Vector Control, SFVC Closed-Loop Vector Control, FVC, Above 3.7kW
	Max. Frequency	0.0-600.0 Hz
	Carrier Frequency	0.5 kHz-8.0 kHz The Carrier Frequency is Automatically Adjusted Based on the Load Features.
	Input Frequency Resolution	Digital Setting      0.01 Hz Analog Setting      Max. Frequency x 0.025%
	Start Torque	G Type      0.5 Hz / 150%, SVC P Type      0.5 Hz / 100%
	Speed Range	1:100, SVC
	Speed Stability Accuracy	±0.5%, SVC
	Overload capacity	G Type      60s for 150% of the Rated Current, 3s for 180% of the Rated Current. P Type      60s for 120% of the Rated Current, 3s for 150% of the Rated Current.
	Torque boost	Auto-Boost; Customized Boost: 0.1%~30.0%
	Ramp Mode	Straight-Line Ramp. Four Groups of Acceleration/Deceleration Time with the Range of 0.00-6500.0s
	DC Braking	DC Braking Frequency      0.00Hz~Maximum frequency Braking Time      0.0s~36.0s Braking Action Current Value      0.0%~100.0%
	JOG control	JOG Frequency Range      0.00 Hz-50.00 Hz JOG Acceleration/Deceleration Time:      0.0s~6500.0s
	Simple PLC, Multiple Preset Speeds	It Implements up to 16 Speeds via the Simple PLC Function or Combination of Terminal States
	Onboard PID	It Realizes Process Controlled Closed Loop Control System Easily
	Auto voltage regulation (AVR)	It Can Keep Constant Output Voltage Automatically when the Mains Voltage Changes
	Overvoltage / Overcurrent Stall Control	The current and voltage are limited automatically during the running process so as to avoid Frequent Tripping Due to Over Voltage/Over Current.
	Rapid Current Limit	It Helps to Avoid Frequent Over Current Faults of the AC Drive.
	Torque Limit and Control	It can Limit the Torque Automatically and Prevent Frequent Over Current Tripping During the Running Process. Torque Control can be Implemented in the FVC Mode.
Individualized Functions	High Performance	Control of Asynchronous Motor are Implemented Through the High-Performance Current Vector Control Technology.
	Rapid Dip Ride Through	The Load Feedback Energy Compensates the Voltage Reduction so That the AC Drive can Continue to Run for a Short Time
	Support for Multiple PG Card	Support for Differential Input PG Card, Resolver PG Card, Rotating Transformer PG Card...
	Rapid Current Limit	It Helps to Avoid Frequent Over Current Faults of the AC Drive.
	Timing Control	0.0-6500.0 min.
	Communication Methods	RS 485 standard, ProfiNet is selectable
Running	Command Source	Operation Panel / Control Terminals / Serial Communication Port You can Perform Switchover Between these Sources in Various Ways.
	Frequency Source	There are Ten Frequency Sources. Digital Setting, Analog Voltage Setting, Analog Current Setting, Pulse Setting, Serial Port Setting. You can Perform Switchover Between these Sources in Various Ways.
	Input Terminal	Standard: 5 Digital Input Terminals (Below 5.5kW)/6 Digital Input Terminals (Above 7.5kW); 1 Analog Input Terminal (Below 5.5kW)/2 Analog Input Terminals (Above 6.5kW); 1 Voltage Input (Only Support for 0-10V, Above 7.5kW), 1 Voltage Input (0-10V) or Current Input (4-20mA)
	Output Terminal	1 High-Speed Pulse Output Terminal (Open-Collector), Above 3.7kW. 1 Relay Output Terminal (Below 5.5kW)/2 Relay Output Terminals (Above 7.5kW) 1 Analog Output Terminal (3.7-5.5kW)/2 Analog Output Terminal (Above 7.5kW), Support for 4-20mA Current Output or 0-10V Voltage Output

# NZ2000



General Purpose, Sensorless Vector Control

- Auto Identification, Simple to use
- PID Process Control, Multi-Function I/O
- Heavy Duty Use (3s 180%, 60s 150%)
- Support MODBUS, EtherCAT is selectable
- Power Range 0.4-280 kW
- Drives AC Induction Motor; Permanent Magnet Synchronous Motor is Selectable



Item		Specifications	
Basic Function	Control Mode	V/F Control Sensorless Flux Vector Control, SFVC	
	Max. Frequency	Vector Control	0.0-320.0 Hz
		V/F Control	0.1-3200 Hz
	Carrier Frequency	1.0 kHz-16.0 kHz The Carrier Frequency is Automatically Adjusted Based on the Load Features.	
	Input Frequency Resolution	Digital Setting	0.01 Hz
		Analog Setting	Max. Frequency x 0.025%
	Start Torque	G Type	0.5 Hz / 150%, SFVC
		P Type	0.5 Hz / 100%
	Speed Range	1:100, SFVC	
	Speed Stability Accuracy	±0.5%, SFVC	
	Overload Capacity	G Type	60s for 150% of the Rated Current, 3s for 180% of the Rated Current.
		P Type	60s for 120% of the Rated Current, 3s for 150% of the Rated Current.
	Torque Boost	Fixed Boost; Customized Boost	0.1%~30.0%
	Ramp Mode	Straight-Line Ramp; S-Curve Ramp Four Groups of Acceleration/Deceleration Time with the Range of 0.00-6500.0s	
	DC Braking	DC Braking Frequency	0.00Hz~Maximum frequency
		Braking Time	0.0s~100.0s
		Braking Action Current Value	0.0%~100.0%
	JOG control	JOG Frequency Range	0.00 Hz-50.00 Hz
		JOG Acceleration/Deceleration Time:	0.0s~6500.0s
	Simple PLC, Multiple Preset Speeds	It Implements up to 16 Speeds via the Simple PLC Function or Combination of Terminal States	
Onboard PID	It Realizes Process Controlled Closed Loop Control System Easily		
Auto voltage regulation (AVR)	It Can Keep Constant Output Voltage Automatically when the Mains Voltage Changes		
Overvoltage / Overcurrent Stall Control	The current and voltage are limited automatically during the running process so as to avoid Frequent Tripping Due to Overvoltage/Over Current.		
Rapid Current Limit	It Helps to Avoid Frequent Over Current Faults of the AC Drive.		
Torque Limit and Control	It can Limit the Torque Automatically and Prevent Frequent Over Current Tripping During the Running Process.		
High Performance	Control of Asynchronous Motor are Implemented Through the High-Performance Current Vector Control Technology.		
Running Command Channel	Given by the Panel, Control Terminals, Serial Communication Port, can be Switched by Many Ways.		
Frequency Source	There are Ten Frequency Sources. Digital Setting, Analog Voltage Setting, Analog Current Setting, Pulse Setting, Serial Port Setting. You can Perform Switchover Between these Sources in Various Ways.		
Auxiliary Frequency Source	10 kinds of Frequency Source, can be easily realize Micro Adjust, Frequency Synthesizer		
Timing Control	0.0-6500.0 min.		
Communication Methods	RS 485, EtherCAT is optional		
Input & Output	Input Terminal	6 Digital Input Terminals, One of Which Supports up to 100 kHz High-Speed Pulse Input (Optional). 2 Analog Input Terminals, One of Which Only Supports 0-10V Voltage Input and the Other Supports 0-10V Voltage Input or 4-20mA Current Input.	
	Output Terminal	1 Digital Output Terminal 1 Relay Output Terminal 1 Analog Output Terminal, That Supports 0-20mA Current Output or 0-10V Voltage Output	
Others	Protection Function	Motor Short-Circuit Detection at Power-On, Output Phase Loss Protection, Over-Current Protection, Overheat Protection and Overload	
	Key Locking and Function Selection	It can Lock the Keys Partially or Completely and Define the Function Range of Some Keys so as to Prevent Mis-Function.	
	Protection Class	IP20	



# NZ8000

High Performance & Powerfull, Heavy Duty

- Various Control Version, V/F, Sensorless Vector and Closed Loop Vector Control
- Modbus RS 485, Profibus-DP, CANopen Communication Mode
- Flexible Programmable I/Os
- Heavy Duty 150% 60s, 180% 3s
- Wide Operating Voltage 220 to 690 VAC

Item		Specifications	
Basic Function	Control Mode	V/F Control Sensorless Flux Vector Control, SFVC Closed-Loop Vector Control, FVC, Above 3.7kW	
	Max. Frequency	Vector Control 0.0-320.0 Hz V/F Control 0.0-3200.0 Hz	
	Carrier Frequency	1.0 kHz-16.0 kHz The Carrier Frequency is Automatically Adjusted Based on the Load Features.	
	Input Frequency Resolution	Digital Setting 0.01 Hz Analog Setting Max. Frequency x 0.025%	
	Start Torque	G Type 0.5 Hz / 150%, SFVC; 0.0 Hz / 180%, FVC P Type 0.5 Hz / 100%	
	Speed Range	1:100, SFVC / 1:1000, FVC	
	Speed Stability Accuracy	±0.2%, SFVC / ±0.02%, FVC	
	Torque Control Accuracy	±5%, Closed-Loop Vector Control FVC Mode	
	Overload capacity	G Type 60s for 150% of the Rated Current, 3s for 180% of the Rated Current. P Type 60s for 120% of the Rated Current, 3s for 150% of the Rated Current.	
	Torque boost	Fixed-Boost; Customized Boost: 0.1%~30.0%	
	Ramp Mode	Straight-Line Ramp.; S-Curve Ramp; Four Groups of Acceleration/Deceleration Time with the Range of 0.00-6500.0s	
	DC Braking	DC Braking Frequency 0.00Hz~Maximum frequency Braking Time 0.0s~100.0s Braking Action Current Value 0.0%~100.0%	
	JOG control	JOG Frequency Range 0.00 Hz-50.00 Hz JOG Acceleration/Deceleration Time 0.0s~6500.0s	
	Onboard Multiple Preset Speeds	It Implements up to 16 Speeds via the Simple PLC Function or Combination of Terminal States	
	Onboard PID	It Realizes Process Controlled Closed Loop Control System Easily	
	Auto voltage regulation (AVR)	It Can Keep Constant Output Voltage Automatically when the Mains Voltage Changes	
	Individualized Functions	Overvoltage / Overcurrent Stall Control	The current and voltage are limited automatically during the running process so as to avoid Frequent Tripping Due to Over Voltage/Over Current.
		Torque Limit and Control	It can Limit the Torque Automatically and Prevent Frequent Over Current Tripping During the Runing Process. Torque Control can be Implemented in the FVC Mode.
High Performance		Control of Asynchronous Motor and Synchronous Motor are Implemented Through the High Performance Current Vector Control Technology.	
Rapid Dip Ride Through		The Load Feedback Energy Compensates the Voltage Reduction so That the AC Drive can Continue to Run for a Short Time	
Support for Multiple PG Card		Differential Input PG Card / Resolver PG Card / Rotating Transformer PG Card UVW Differential Input PG Card / OC Input PG Card	
Rapid Current Limit		It Helps to Avoid Frequent Over Current Faults of the AC Drive.	
Timing Control		0.0-6500.0 min.	
Running	Communication Methods	Modbus (Standrad), Profibus-DP, CANopen	
	Running Command Source	Operation Panel / Control Terminals / Serial Communication Port You can Perform Switchover Between these Sources in Various Ways.	
	Frequency Source	Digital Setting, Analog Voltage Setting, Analog Current Setting, Pulse Setting, Serial Port Setting. You can Perform Switchover Between these Sources in Various Ways.	
	Input Terminal	8 Digital Input Terminals, One of Which Supports up to 100 kHz High-Speed Pulse Input 2 Analog Input Terminal, One of Which Only Supports 0-10V Voltage Input and the Other Supports 0-10V Voltage Input or 4-20 mA Current Input.	
	Output Terminal	1 High-Speed Pulse Output Terminal (Open-Collector) that Supports 0-100kHz Square Wave Signal Output 1 Digital Output Terminal 2 Relay Output Terminal 2 Analog Output Terminal - that Supports 0-20mA Current Output or 0-10V Voltage Output.	
Protection Function	Motor shourt-circuit detection at power-on, output phase loss, over-current, overheat, under voltage and overload		

# NZS Power range Max. up to 110 kW

IP65/IP54 Class, V/F and Sensorless Vector Control

- High Level Protection Class, Outdoor Application
- Various Version Control Mode, V/F and SFVC
- Pumps Application/General Purpose Selectable
- Compact, Rugged Design. It can be Directly Installed on the Motors or on Virtually any Other Mounting Surface Based on the Application Requirements.
- Master/slave system makes this easy to set pumps

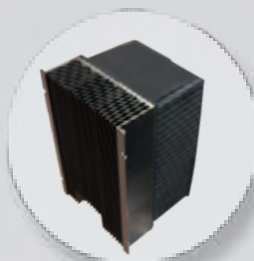

Coated heatsink as Standard



Item		General Purpose Version		Pumps Application Version	
Basic Function	Control Mode	V/F Control / Sensorless Flux Vector Control Selectable		V/F Control, Space Vector Control	
	Max. Frequency	Vector Control	0.0-320.0 Hz	0.1-400 Hz	
	Carrier Frequency	V/F Control	0.1-3200 Hz		
	Carrier Frequency	1.0 kHz-16.0 kHz The Carrier frequency is automatically adjusted based on the load features.		1.0 kHz-15.0 kHz	
	Input Frequency Resolution	Digital Setting	0.01 Hz	Digital Setting	0.1 Hz
	Input Frequency Resolution	Analog Setting	Max. Frequency x 0.025%	Analog Setting	Max. Frequency x 0.1%
	Start Torque	G Type	0.5 Hz / 150%, SFVC	0.5 Hz / 100%	
	Start Torque	P Type	0.5 Hz / 100%		
	Speed Range	1:100, SFVC		/	
	Speed Stability Accuracy	±0.5%, SFVC		/	
	Overload Capacity	G Type	60s for 150% / 3s for 180% of rated current	60s for 120%/3s for 150% of rated current	
	Overload Capacity	P Type	60s for 120%/3s for 150% of rated current		
	Torque Boost	Fixed Boost; Customized Boost 0.1%~30.0%		Auto-raise torque by loading condition; Manual increase 0.0-20% of rasing torque	
	Ramp Mode	Straight-Line Ramp; S-Curve Ramp 4 Groups of Acceleration/Deceleration Time with the Range of 0.0-6500.0s		Straight-Line Ramp, the Range of 0.0-999.9.0s	
	DC Braking	DC Braking Frequency	0.0 Hz-Max.frequency	DC Braking Frequency	0.0-10.0Hz
		Braking Time	0.0s~100.0s	Braking Time	0-25.0s
JOG control	Braking action current value	0.0~100.0%	Braking action current value	0-150%	
	Frequency Range	0.00 Hz-50.00 Hz	Frequency range	0.0 Hz-Max.frequency	
Simple PLC, Multiple Preset Speeds	Acce-tion/deceleration time	0.0-6500.0s	Acce-tion/deceleration time	0.0-999.9s	
	It implements up to 16 speeds via the simple PLC Function or combination of terminal states		4 multiple terminals, It implements up to 15 speeds		
Onboard PID	It realizes process Controlled Closed Loop Control system easily		Built-in PID		
Auto voltage regulation (AVR)	It can keep constant output voltage automatically when the mains voltage changes		Automatic voltage regulation function can be selected as required		
Overvoltage / Overcurrent Stall Control	The current and voltage are limited automatically during the running process so as to avoid frequent tripping due to overvoltage/over current.		The overvoltage protection can be set		
Frequency Source	There are 10 frequency sources. digital set, analog voltage set, analog current set, pulse set, serial port set, you can perform switchover between these Sources in various ways.		Analog input 0 to 10V, 0to 20mA can be selected directly set by keyboard, RS485 set, up/down set and others various ways		
Input & Output	Input Terminal	6 Digital Input Terminals, 1 of which supports up to 100 kHz high-speed pulse Input (Optional).2 analog input terminals, 1 of which only supports 0-10V voltage Input and the other supports 0-10V voltage Input or 4-20mA current input.		4 multi-function Input terminals, 1 analog input terminal, supports 0-10V voltage input or 4-20mA current input.	
	Output Terminal	1 digital output terminal 1 relay output terminal 1 analog output terminal, that supports 0-20mA or 0-10V		2 relay output terminal (0.75-5.5 kW) 1 relay output terminal (7.5kw and above)	
Others	10 kinds of frequency source, can easily realize micro adjust, frequency synthesizer		Built-in 2 groups of counters		
Protection Function	Motor short-circuit detection at power-on, output phase loss, over-current, overheat, under voltage and overload				
Communication Methods	RS 485				
Protection Class	IP54 ( Above 3.7kw) /IP65 ( below 3.7kw), outdoor				
Mounting Mode	Mounted on the motor or on wall				
Indication	LED indiction parameters				
Vibration feature	less 5.9 m/s <sup>2</sup> (0.6g)				



# PDS-7

Pumps Drives -Wall-Mounted Type  
220 / 380VAC; 1HP - 3HP

- Compact, Directly Mounted on Motors
- Using DSP high-speed digital processor and high-performance IGBT, the circuit is mature and the performance is stable.
- Easy to Use, Suitable to Any Pumps
- Built-in PID, PLC; Max.Frequency up to 999.9 Hz
- V/F Control Mode; Performance Load Capacity

Item		Specifications		
Power Supply	Rated Voltage	220 VAC, 50/60Hz, 1 Phase Input and 3 Phase Output 380 VAC, 50/60Hz, 3 Phase Input and 3 Phase Output		
	Voltage Range	220 VAC 380 VAC	170-240 VAC 330-440 VAC	
Output	Voltage Range	220 VAC 380 VAC	0-240 VAC 0-380 VAC	
	Frequency Range		0.0-999.9 Hz	
Control Mode		V/F Control		
Carrier frequency setting		0.5-16.0 kHz		
Basic Specification	Output Frequency Range	0.0-999.90 Hz		
	Frequency Setting Resolution	Digital Input Analog Input	0.1 Hz 0.025% of Max. Output Frequency	
	Startup Torque	G type P type	0.5 Hz /150% 0.5 Hz / 100%	
	Speed Range	1:100		
	Overload Capacity	G type P type	150% of rated current, 60s; 180% of rated current, 3s 120% of rated current, 60s; 150% of rated current, 3s	
	Torque Boost	Manual mode 0.1%~30.0%		
	Acceleration & deceleration curve time	0-999.9s, 4 types acceleration/deceleration time		
	DC Braking	DC Braking Frequency	0.0 Hz-Max.frequency	
		Braking Time	0.0-36.0s	
		Braking action current value	0.0~100.0%	
	JOG control	JOG frequency range	0.0Hz~50.00Hz	
		Acceleration/deceleration time	0.0s~999.9s	
	Multi-Speed, PLC operation	It implements multi-speeds via the built-in PLC function or combination of terminal states		
	Onboard PID software	Integrated enhanced PID control algorithm: with sleep, wake-up, antifreeze, disconnection detection, high and low pressure alarm, water shortage detection, automatic operation after water supply / fault reset and other functions		
	Automatic Voltage Regulation	It can keep constant output voltage automatically when the mains voltage changes		
Communication	RS-485			
Protection Functions	I/O phase loss protection, over current protection, over voltage protection, under voltage protection, overheat protection and overload protection			
Input & Output, others	Input Terminals	2 digital input terminals; 2 analog,each of which supports 0~10V or 4~20mA current input;		
	Frequency Source	Digital, analog voltage, analog current, serial port. Can be switching in various ways.		
	Command Source	Operation panel/Control terminals/Serial communication port		
	Output Source	1 transistor output terminal 1 relay output terminal		
	Protection Class	IP20		
Installation Mode	Mounted on the Motor Directly or Wall-Mounted			

PDS-7 wall-mounted frequency converter for fixed-speed equipped with asynchronous motors. Its a new generation of high-end intelligent integrated compact water supply special products independently researched & developed by NIETZ.

It can be installed on various brands of Pump Motor terminalboxes, and can be accessed in various types of sensor signal, saving panel space and cost.

- Newly developed SOFTWARE 2.0 platform, using modular design, software performance is excellent and stable.
- Adopt a new space vector algorithm with a reliable protection mechanism.
- Integrated enhanced PID control algorithm: with sleep wake-up, antifreeze, disconnection detection, high & low pressure alarm, water shortage detection, water shortage shutdown, automatic operation after water supply, automatic fault reset and other functions.
- Featuring simple operation, good reliability, low noise and high performance.

## TECHNICAL FEATURES

	Power, kW	Main Circuit Wire Diameter, mm <sup>2</sup>	Air Circuit Breaker, A	Electromagnet Contactor, A	Rated Input Current, A	Rated Output Current, A
220V ±15% 1 Phase Input, 3 Phase output	0.75	1.0	25	13	7.2	5
	1.5	1.5	25	18	10	7
	2.2	2.0	25	25	13	9
380V ±15% 3 Phase Input, 3 Phase output	0.75	0.5	10	6	3.5	2.1
	1.5	1.0	10	9	5	3.7
	2.2	1.0	10	10	5.8	5



# WVP9

## Multi-Pumps Control

- V/F Control, Sensorless Vector Control
- Controls max. 4 water pumps after add relay output
- Heavy Duty Use (3s 180%, 60s 150%)
- Support MODBUS via RS485
- 24 VDC power supply support to Current sensor
- STO Function more Efficient Protect the Pumps



### Advantage and Features

WVP-9 multiple pump Variable Speed Drive is for controls multi-pumps, max. 4 in parallel. The inverter selects which pumps will operate in order to keep/control the process value of the pumping system. An alternation between their activation is also performed, making it possible an equal use of the pumps.

#### ► Features

- Full protection for pumping systems and maximized usability through special functions. The ▲▼ key directly adjusts the target pressure.
- Power off, then when the power is restored, it will automatically restart the running function.
- Extended relay output can achieve one inverter control 4 constant pressure water supply pump.
- 24VDC power supply to power the current sensor. The Drive has the intelligent judgment function of dormancy.
- English keyboard displays target value and feedback value.
- It can be extended to 4 pumps for water supply, including stabilized pressure pump and variable frequency pump.
- It supports the online selection function of feed-1 pump and 1 frequency conversion linkage control completes constant pressure water supply function.
- The keyboard can start the constant pressure water supply control function, can have the stop function and the fault reset function.

#### Security Alarm Function ◀

- High water pressure alarm function, low water pressure alarm function
  - Protection function of water shortage
  - Antifreeze function
  - Detect sensor disconnection
  - Automatic reset of water shortage fault
- Multi-pump control, fault pump is manually cut off



Optional Water Supply Card can be control Max. 4 pumps

Item	Specifications	
Control Mode	V/F Control, Sensorless Vector Control	
Max. Frequency	0.0-600.0 Hz	
Carrier Frequency	0.5 kHz-12.0 kHz The Carrier Frequency is Automatically Adjusted Based on the Load Features.	
Input Frequency Resolution	Digital Setting	0.01 Hz
	Analog Setting	Max. Frequency x 0.025%
Start Torque	G Type	0.5 Hz / 150%
	P Type	0.5 Hz / 100%
Speed Range	1:200	
Speed Stability Accuracy	±0.5%, SFVC	
Overload Capacity	G Type	60s for 150%; 3s for 180% of rated current
	P Type	60s for 120%; 3s for 150% of rated current
Torque Boost	Auto-boost; Manuals adjust range 0.1%~30.0%	
V/F Curve	Linear/ Multi-Point and N-th Power V/F Curve	
V/F Separation	Full Separation and Half Separation	
Ramp Mode	Straight-Line Ramp; S-Curve Ramp	
	4 Groups of Acceleration/Deceleration time 0.0-6500.0s	
	DC Braking	DC Braking Frequency 0.0Hz to Max. frequency
JOG control	Braking Time	0.0s~36.0s
	Braking Action Current Value	0.0%~100.0%
	JOG Frequency Range	0.00 Hz-50.00 Hz
Simple PLC, Multiple Preset Speed	JOG Acceleration/Deceleration Time	0-6500.0s
	Onboard PID	It Implements up to 16 Speeds via the Simple PLC Function or Combination of Terminal States
Auto voltage regulation (AVR)	It Realizes Process Controlled Closed Loop Control System Easily	
Overvoltage/Overcurrent Stall Control	It Can Keep Constant Output Voltage Automatically when the Mains Voltage Changes	
Rapid Current Limit	The current and voltage are limited automatically during the running process so as to avoid frequent tripping due to overvoltage/over current.	
Torque Limit and Control	It Helps to Avoid Frequent Over Current Faults of the AC Drive.	
Multi-Pumps control	It can Limit the Torque Automatically and Prevent Frequent Over Current Tripping During the Running Process.	
Running Command Channel	Can realize 1 control 2-3, add expansion water supply card, can realize max.4 pumps	
Frequency Source	Given by the Panel, Control Terminals, Serial Communication Port, can be Switched by Many Ways.	
Auxiliary Frequency Source	10 Frequency Sources. Digital, Analog Voltage, Analog Current, Pulse, Serial Port. You can Perform Switchover Between these Sources in Various Ways.	
Timing set/ Communication	10 Multiple Auxiliary frequency source. Flexible realization of auxiliary frequency fine-tuning and frequency synthesis.	
Input Terminal	0.0-6500.0 min./ RS485	
	6 Digital Input terminal	
	2 Analog Input Terminals, 1 of Which Only Supports 0-10V and the Other Supports 0-10V or 4-20mA	
Output Terminal	1 Digital Output Terminal MO1	
	2 Relay Output Terminal RA, RB, RC/TA, TC	
	2 Analog Output Terminal, That Supports 0-20mA Current Output or 0-10V Voltage Output	
Protection Function	Output phase loss, overcurrent, overvoltage, undervoltage, overheat, overload protections, etc.	



# APV

Integrated Pumps Drives -Wall-Mounted Type  
220 / 380VAC; 1HP - 3HP

- Compact, Directly Mounted on Motors
- Robust Enclosure, High Protection Class
- Easy to Use, installation
- Advanced Pumps Control Function
- V/F Control; Max. output frequency 999.9 Hz

## APV - Integrated Pumps Control

APV is a new generation of high-end intelligent integrated ultra-high protection water supply special products independently researched and developed by NIETZ

The Variable Speed Drives is dustproof and waterproof, and can be installed on various brands of pump motor terminal boxes, and can be accessed in various types of sensor signal. Can be use in dirty and damp environments, even with low pressure jets; saving panel space and cost.

- Compact & Robust
- Easy to use, directly mounted on motor pumps.
- Protection class IP65, can be use at outdoor, dusty, moist
- In order to mechanically install the drive controller on the motor, the adapter is used in place of the terminal box. any motor can be adapted.



### Motor adapter plate

In order to mechanically install the drive controller on the motor, the adapter is used in place of the terminal box. any motor can be adapted.



	Power, kW	Main Circuit Wire Diameter, mm <sup>2</sup>	Air Circuit Breaker, A	Electromagnet Contactor, A	Rated Input Current, A	Rated Output Current, A
220V ±15% 1 Phase Input, 3 Phase output	0.75	0.75	16	12	7.2	4.5
	1.5	1.5	25	18	10	7
	2.2	2.5	32	25	16	10
380V ±15% 3 Phase Input, 3 Phase output	0.75	0.75	6	9	3.8	2.5
	1.5	0.75	10	9	5	3.7
	2.2	0.75	10	9	5.8	5

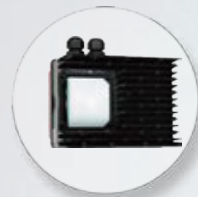

Compact & robust Aluminum heat sink Simple mounting on motor



### Dimension, mm

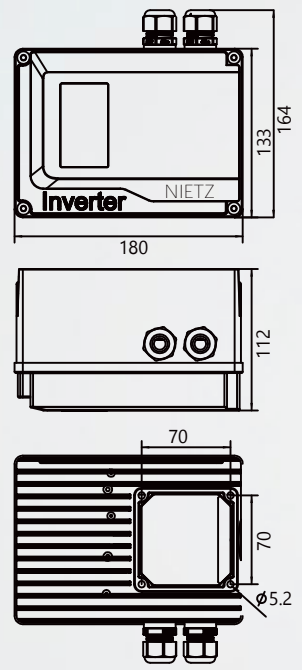

# CV20

Solution for Industrial Crane and Hoist

- Sensorless Vector Control, Closed-Loop Vector Control
- Professional brake timing control; start and stop smoothly without slipping the hook to prevent the cargo from sliding down
- Intelligent anti-sway, Load holding function
- Built-in Brake Unit, Heave Duty



### Professional brake timing control

According to the frequency, output current and torque of the inverter, the brake release command will be output. When starting and stopping, keep the necessary torque to stabilize the cargo, and open the holding brake, and start / stop smoothly without slipping



### Brake failure detection

When the stop brake is valid, the encoder is used to detect whether the brake is invalid. If it fails, the inverter is automatically started to maintain torque to prevent accidents (Valid Closed Loop).

### Light load speed increase adaptive

Through the light load speed-increasing function, the best running speed matching the load can be achieved. When the load is light, it allows automatic speed increase and improves efficiency, no auxiliary hook design is required, which can shorten the operating period of the crane with a long head.

### Intelligent anti-sway

With built-in anti-sway function, so can suppress the shaking of the goods during translation. Since the load does not sway, it can be laid down faster, which is beneficial to shorten the operating cycle. CV20 drives with integrated sensorless control functionality enhance productivity and safety by avoiding sway in cranes.

### Stroke Limit Control

By the limit sensor input can prevent the hook from overtraveling and excessive hoisting.

### Open and Closed Loop Control

CV20 drives help to ensure excellent open-loop crane performance without encoders. Travel and hoist commissioning is simple. Droop control equalizes torque between the two motors operating in parallel. Closed loop control offers even better crane dynamics. We offer flexible encoder interfaces for broad component choice.



### Crane Types Served

- Bridge crane, Overhead crane, Process crane
- Rail-mounted gantry crane, Goliath crane
- Rubber tired gantry crane, RTG crane, Grab crane
- Marine crane, Mobile crane, Mobile harbor crane
- Ship to shore crane (STS crane), container crane
- Tower crane, Construction hoist, Port Crane



## Advantage and Features

CV20 AC drives with built-in crane control software, brake unit and range of safety functions help various types of cranes move efficiently. Our CV20 drives are an excellent choice for standalone cranes

CV20 series inverter special for hoisting is tailor-made for various severe application conditions in the hoisting industry, and it can easily solve technical and performance problems.

CV20 adopts vector frequency conversion control technology, while maintaining excellent performance and function, from the perspective of lifting application, it is superior in terms of ease of use, maintainability, environmental protection, installation space and design standards to similar products. With high-performance current vector technology, it can easily drive asynchronous induction motors to meet the working requirements in various environments

### ► Features

- **Rope Length Detection**  
The height information of the hook can be seen in the cab just by the inverter. When the wire rope reaches the set length, the collision with the lifting drum can be avoided by reducing the ascent and descent speed.
- **Rapid Deceleration**  
By inputting a quick stop command through the terminal, it can perform rapid deceleration near the target position.
- **Load Holding Function**  
When stopped, the load can be kept at the current position through zero-speed control. Close the brake when it is stable.
- **Overload Detection**  
The torque rise value is detected when the cargo accidentally contacts other objects. At this time, the motor can be automatically stopped to prevent accidents and improve safety.
- **Self-Tuning Motor Parameter**  
It can accurately identify asynchronous induction motors and achieve high-performance vector control; It can achieve accurate setting of motor parameters of long-distance over cables under load, and can automatically discriminate encoder signal directions under encoder conditions, simplifying the debugging process.
- **Parameter macro**  
The function to select the purpose according to the crane action. Just select hoist, long travel, trolley and other uses, you can automatically set the necessary and unnecessary functions to be valid or invalid. The best parameters can be set simply for different purposes.



## ESD / ESD2

For Small Power AC Motors

- Mini Dimension, Low Cost
- Potentionmeter Knob to Covenient Adjust to Speed Regulation, Optimized Structure
- ESD2 series Support MODBUS via RS485
- V/F Control; 220V, Easy to use
- Frequency Range 1.0...99.0Hz/ 0.0...300.0Hz

## ESD2 Variable Speed Drives

ESD2 series frequency inverter is a new generation micro power variable speed drive, specially designed for small power motor. Micro dimension, save installation space, instrument embedded structure, installation is simple and compact.

### Advantage and Features

- Power range: 0.2~1.1 kW / 220V; V / F type control
- Input / output: single / three phase
- Output frequency range 0-300 Hz, analog input 0-5 V
- Carrier frequency up to 38.4 kHz
- Built-in MODBUS RS485, baud rate up to 9600 bps
- Forced air cooling
- Potentiometer knob to convenient adjust to speed regulation, optimized structure, forced air cooling
- Adopt a new generation I P M module with complete protection functions

### DIMENSION

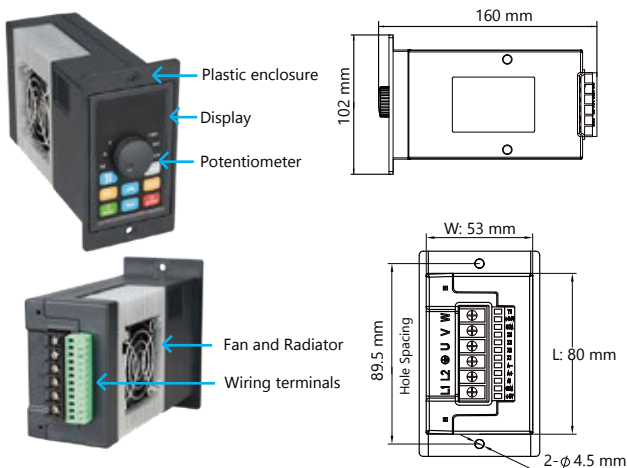

## ESD Variable Speed Drives

ESD frequency inverter is embedded small power inverter, specially designed for small power motor. Small dimension, save installation space, instrument embedded structure, installation is simple and easy to use.

### Advantage and Features

- Power range: 0.4~0.75 kW / 220V; V / F type control
- Input / output: single / three phase
- Output frequency range 1-99 Hz
- With speed adjust potential device, also can outer connect speed adjust potential device;
- Built-in MODBUS RS485, baud rate up to 9600 bps
- Interior configured intelligent logic controller can realize the simple, easy logic control function.
- With electric thermal electric relay function and other traditional motor protection device;
- Can outer connect LED for indicate, convenient for field use requirements;
- Humanization operating interface, simple and clear the parameters setting, convenient for operating;

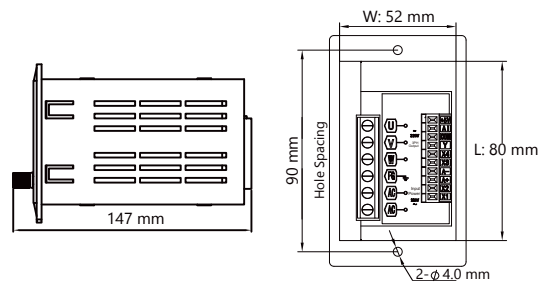

### Typical Applications

Suitable for electronic equipment, package equipments, wood cutting machine, transportation belt, wire drawing machine, etc.



# AMD

AC Spindle Servo Drives / 380V, 0.4-160 kW

- V/F Control, SFVC, FVC Control Mode
- Controls AC Induction, Spindle Asynchronous Motor
- Support Various Optional Encoder
- Easy and flexible control; MODBUS RS485
- Incredible Performance of Speed, torque and position control; All protection



AMD series spindle servo drives is designed for numerical control machine of new type and high precision and it has new functions like positioning control, pulse synchronous control and so on. It supports FEEDBACK vector control towards the spindle motor with encoder. This drive has high responding ability towards speed as well as smooth speed. It can achieve various functions like warrant stop of spindle; Rigid tapping; indexing positioning and so on by cooperating with different numerical control system.

## ► Features

- Multi encoder support; it can support differential encoder; ABZ encoder and so on.
- Power dip ride-through, load feedback energy compensates for any voltage reduction, allowing the drive to continue to operate for a short time during power dips.
- Overvoltage and overcurrent stall control; the system limits the output current and voltage automatically during operation to prevent frequent or excessive trips.
- Torque limit and control: the system limits the torque automatically to prevent frequent over-current tripping during operation. Torque control is applied in vector control.
- Onboard multiple preset position: the system implements up to 16 position by using simple PLC function or by using digital input signals.

Item	Specifications	
Control Mode	V/F Control, Sensorless Vector Control, Closed-Loop Vector Control	
Motor Types	3 Phase Induction Motor	Spindle Asynchronous Motor
Max. Frequency	V/F control mode	0-1500 Hz
	Vector control mode	0-1000 Hz
Carrier Frequency	0.8-16.0 kHz Adjust the frequency automatically according to loading characteristics.	
Input Frequency Resolution	Digital Setting	0.01 Hz
	Analog Setting	Max. Frequency x 0.025%
Start Torque	G Type -0.5 Hz / 150% (SFVC) / 0.0 Hz / 180% ( FVC)	
Speed setting Range	1:100 SFVC	1:1000 FVC
Speed Stability Accuracy	±0.5%, SFVC	±0.2%, FVC
Overload Capacity	G Type	60s for 150%; 3s for 180% of rated current
	P Type	60s for 120%; 3s for 150% of rated current
Torque Boost	Auto-boost; Manuals adjust range 0.1%~30.0%	
V/F Curve	Linear/ Multi-Point and N-th Power V/F Curve	
Ramp Mode	Straight Line Ramp; 4 Groups of Accel-eration/Decel-eration time 0.0-6500.0s	
DC Braking	DC Braking Frequency	0.0Hz to Max. frequency
	Braking Time	0.0s~36.0s
	Braking Action Current Value	0.0%~100.0%
Simple PLC, Multiple Preset Speed	It Implements up to 16 Speeds via the Simple PLC Function or Combination of Terminal States	
Auto voltage regulation (AVR)	It Can Keep Constant Output Voltage Automatically when the Mains Voltage Changes	
Overvoltage/ Overcurrent Stall Control	The current and voltage are limited automatically during the running process so as to avoid frequent tripping Due to Overvoltage/Over Current.	
Rapid Current Limit	It can decrease the over-current fault on a maximum extent, thus protecting the normal operation of the spindle servo driver.	
Torque Limit and Control	It can Limit the Torque Automatically and Prevent frequent Over Current Tripping During the Running Process. Can be adjust the torque through FVC control mode.	
Optional support PG cards	Differential input PG card	Open collector
	Rotating transformer PG card	
Running Command Channel	Given by the Panel, Control Terminals, Serial Communication Port, can be Switched by Many Ways.	
Auxiliary Frequency Source	Multiple Auxiliary frequency source. Flexible realization of auxiliary frequency fine-tuning and frequency synthesis	
Timing set	0.0-6500.0 min.	
Communication	ModBus RS485	
Input Terminal	6 Digital Input terminal 2 Analog Input Terminals, 1 of Which Only Supports 0-10V and the Other Supports 0-10V or 4-20mA	
Output Terminal	1 Digital Output Terminal	MO1
	2 Relay Output Terminal	RA, RB, RC, YA, YB, YC
	1 Analog Output Terminal, That Supports 0-20mA Current Output or 0-10V Voltage Output	
Protection Function	Output phase loss, overcurrent, overvoltage, undervoltage, overheat , overload protections, etc.	

Basic Function

## TYPICAL APPLICATION

- CNC lathe, turn-milling machine tool, vertical lathe, Heavy duty horizontal lathe
- Drilling and tapping center, engraving and milling machine, gear hobbing machine, gear shaping machine, gear milling machine





# AT10 series Electrohydraulic Servo Drive



- Built-in CAN, MODBUS RS485 communications
- Support single, double and multiple electro hydraulic pump system
- Variety of signal reference modes, more saving energy
- Built-in Brake unit. Heavy Duty, 150% in 60s; 180% in 5s.
- Voltage Supply 220 ~ 380 VAC; Powerfull 7.5 ~ 450 kW
- Various protection functions such as phase loss, short circuit, overheating detection and etc.
- High-performance servo control: Vector control + field weakening control + PID control
- Support 0-10V DC / 4-20mA direct analog signal input
- Fast and safe isolated terminal wiring
- Performance Start torque: 0Hz 180%; Steady speed accuracy:  $\pm 0.02\%$ ; Torque control accuracy:  $\pm 5\%$
- Air cooling, liquid cooling way, Flexibility to use

Electro-Hydraulic ServoSystem combined both electrical and hydraulic characteristics can accurately follow the command changes to adjust the output. With high precision, fast response, big output power, flexible signal processing, easy to control, etc., it is widely used in various industries such as in Injection molding machines, hydraulic presses, stamping and bending machines, etc.

## ▶ ADVANTAGE

- ✓ **Save Energy Consumption**  
Optimized pressure and flow control algorithm saving energy max. 80%
- ✓ **High Precision, Intelligence**  
Multiple Control modes of speed loop, current loop and pressure loop to ensure high precision repeatability.
- ✓ **Noise Reduction**  
Efficient reduction of Noise, less than 65dB improve equipments usage environment
- ✓ **Save Volume and Place**  
Suitable PM Synchronous Motor, Compact size Compared with the open hydraulic circuit, save 75% tank volume

Item	Specifications	
Control Mode	V/F Control / Closed Loop Vector Control	
Carrier frequency setting	1-12.0 kHz Automatically adjust the carrier frequency according to the load characteristics.	
Basic Specification	Output Frequency Range	0.0-599.00 Hz
	Frequency Setting	Digital Input 0.1 Hz
	Resolution	Analog Input 0.025% of Max. Output Frequency
	Startup Torque	0.0 Hz /180%
	Speed Range	1:1000 ( FVC Mode Control)
	Overload Capacity	150% of rated current, 60s; 180% of rated current, 5s
	Torque Control Accuracy	$\pm 5\%$ ( FVC Mode Control)
	Steady Speed Accuracy	$\pm 0.02\%$ ( FVC Mode Control)
	Acceleration and deceleration curves	Linear acceleration and deceleration. 4 kinds of acceleration and deceleration time, plus or minus time range 0.0 ~ 6500.0s.
	Fast Current Limiting Function	Min. Overcurrent faults, Protect the ServoDrive to normal operation
	Encoder Support	Resolver Encoder
	Overvoltage/ Overcurrent Stall Control	Automatically limits the current and voltage during running to avoid frequent tripping caused by overvoltage / overcurrent.
	Communication	RS-485 and CANbus
Protection Functions	I/O phase loss protection, over current protection, over voltage protection, under voltage protection, overheat protection and overload protection	

## Typical Applications

- Air compressor, Pumping unit in oil field, etc.
- Injection molding machines, hydraulic presses, stamping and bending machines, etc.



## ▶ Flow-Converging and Dividing System

### Multi-Pump Flow-Converging System

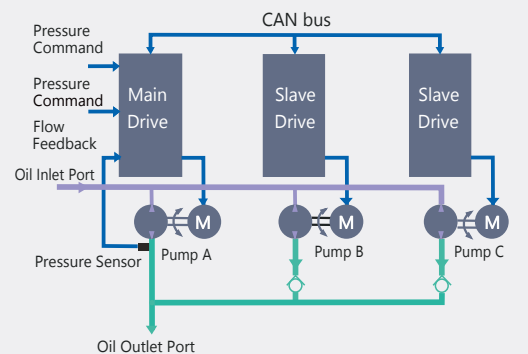

### Multi-Pump Distributed Flow System

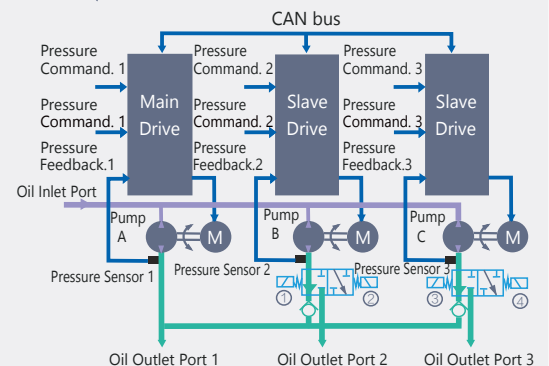

- Set the same speed for motors through communication
- Control the convergent/distributed flow of pumps 2 and 3 by powering on and off solenoid valves ①, ②, ③, and ④
- When the convergent flow control is enabled, the pressure and flow references and pressure feedback signals received by slave drives are invalid.
- When the distributed flow control is enabled, the CAN communication references received by slave drives are invalid.

### Main Circuit Terminal Description

⊕ +/B1	220V, 3 Phase, 7.5 ~ 18.5 kW and 380V, 3 Phase, 7.5 ~ 37 kW	⊕ R	220V, 3 Phase, 22 ~ 30 kW and 380V, 3 Phase, 45 ~ 55 kW
⊕ B2		⊕ S	
⊕ R/L1		⊕ T	
⊕ S/L2		⊕ -	
⊕ T/L3		⊕ +/B1	
⊕ U/T1		⊕ B2	
⊕ V/T2	220V, 3 Phase, 7.5 ~ 110 kW and 380V, 3 Phase, 132 ~ 160 kW	⊕ U	220V, 3 Phase, 75 kW and 380V, 3 Phase, 132 ~ 160 kW
⊕ W/T3		⊕ V	
		⊕ W	

⊕ R	220V, 3 Phase, 55 kW and 380V, 3 Phase, 75 ~ 110 kW	⊕ R	220V, 3 Phase, 75 kW and 380V, 3 Phase, 132 ~ 160 kW
⊕ S		⊕ S	
⊕ T		⊕ T	
⊕ +/B1		⊕ B2	
⊕ B2		⊕ -	
⊕ -		⊕ +/B1	
⊕ U	220V, 3 Phase, 7.5 ~ 110 kW and 380V, 3 Phase, 132 ~ 160 kW	⊕ U	220V, 3 Phase, 75 kW and 380V, 3 Phase, 132 ~ 160 kW
⊕ V		⊕ V	
⊕ W		⊕ W	

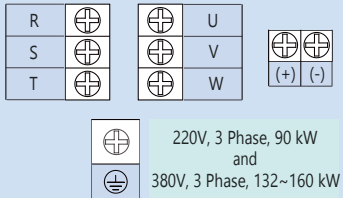

Terminal Code	Function
R/L1, S/L2, T/L3	Voltage Input
U/T1, V/T2, W/T3	Output Terminal of Drive Connect to AC Motor 3 ph.
+/B1, -	DC Power + / -; Can be connect to Brake Unit
+/B1, B2	Connect to Brake Resistance
⊕	Ground Terminal
(+) / (-)	Brake Unit Terminal

### Main Circuit Wiring Example

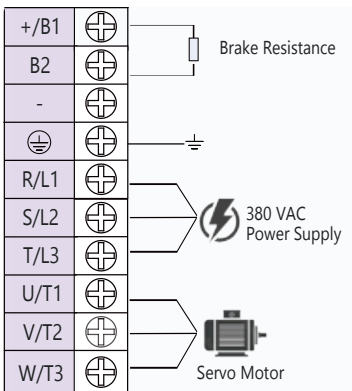

### Power Supply

Power Supply	Power, kW	Rated Input Current, A	Rated Output Current, A
220V ±15% 3 Phase	7.5	35	32
	11	46.5	45
	15	62	60
	18.5	76	75
	22	92	90
	30	113	110
	37	157	152
	45	180	176
	55	214	210
	75	307	304
90	345	340	

Power Supply	Power, kW	Rated Input Current, A	Rated Output Current, A
380V ±15% 3 Phase	7.5	20	17
	11	26	25
	15	35	32
	18.5	38	37
	22	46	45
	30	62	60
	37	76	75
	45	92	90
	55	113	110
	75	157	150
	90	180	176
	110	214	210
	132	256	253
	160	307	300
	185	355	340
	200	385	380
220	430	420	
250	468	470	
280	525	520	
315	610	600	
350	665	640	
400	700	690	

### Wiring Diagram

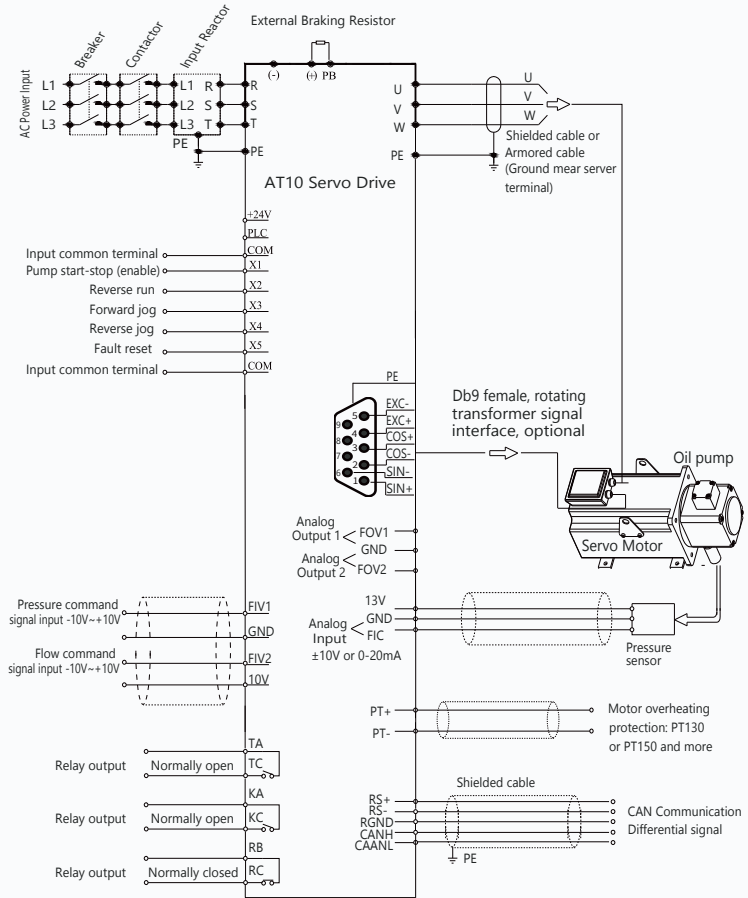

### External Optional

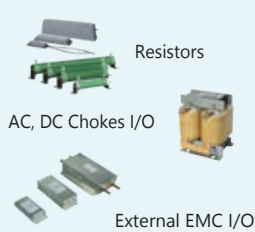

### Resolver Encoder Terminal Arrangement and Definition

Terminal	Signal	Definition
1	REF-	Resolver excitation "-"
2	REF+	Resolver excitation "+"
3	COS+	Resolver feedback COS "+"
4	COS-	Resolver feedback COS "-"
5	SIN+	Resolver Feedback SIN "+"
6	/	/
7	/	/
8	/	/
9	SIN-	Resolver feedback SIN "-"

### Model Code Description

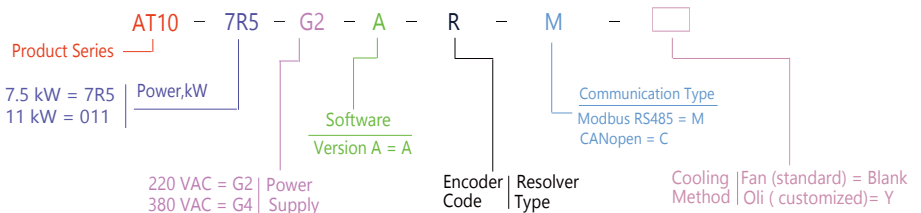

# Micro AC Drive

High Performance General Purpose

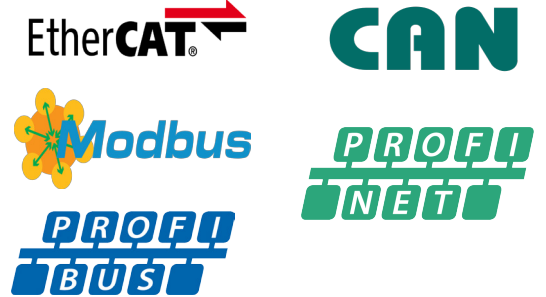

The FC1000 family offers a compact AC drive that combines easy operation with high-efficiency control for AC induction, PMS motor. The robust compact designed, various controls mode, support EtherCAT, Modbus, Profibus-DP communication, built-in EMC filter, 24DC, STO function, Extension PG Cards.....

- Cost Effective; Micro Compact Design
- Easy to use and install; DIN rail mount, RJ45 interface keypad cable
- Integrated safety - Safe Torque Off feature
- Built-in EMC Filter, 24VDC power resource, PID
- V/F, Sensorless Vector, Closed-Loop Vector Controls mode
- Frequency range 0~599Hz; Power Range 0.4~15 kW
- Automatic Voltage Regulation; Performance Load features
- Support Various Extension Cards; EtherCAT, Profibus-DP, Modbus TCP, Digital I/O
- External Keypad copy function and automatic parameter back-up

## Ordering Guide

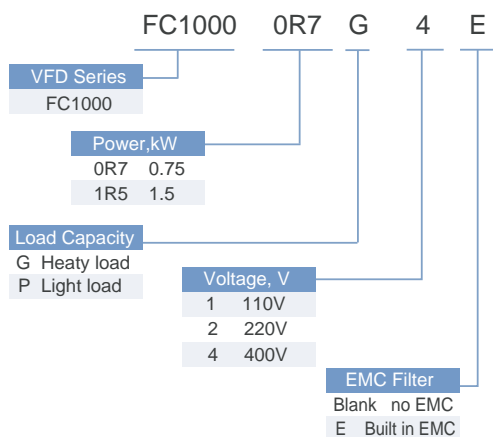

## Model Number and Ratings

Model	Rated output power, kW	Rated input Current, A	Rated output Current, A	Motor power kW
<b>220VAC±15%; Single phase</b>				
FC1000-0R4G2	0.4	5.4	2.1	0.4
FC1000-0R7G2	0.75	7.2	3.8	0.75
FC1000-1R5G2	1.5	10	7.2	1.5
FC1000-2R2G2	2.2	16	9.0	2.2
FC1000-3R7G2	3.7	23	13.0	3.7
<b>380VAC±15%; 3 phase, input voltage</b>				
FC1000-0R4G4	0.4	3.4	1.5	0.4
FC1000-0R7G4	0.75	3.8	2.1	0.75
FC1000-1R5G4	1.5	5.0	3.8	1.5
FC1000-2R2G4	2.2	5.8	5.1	2.2
FC1000-3R0G4	3.0	8.5	7.2	3.0
FC1000-3R7G4	3.7	10	9/13	3.7
FC1000-5R5G4	5.5/7.5	15/20	13/17	5.5/7.5
FC1000-7R5G4	7.5/11	20/26	17/25	7.5/11
FC1000-11G4	11/15	26/35	25/32	11/15
FC1000-15G4	15/18.5	35/38	32/37	15/18.5
FC1000-18G4	18.5/22	38/46	37/45	18.5/22
FC1000-22G4	22/30	46/60	45/60	22/30
FC1000-30G4	30/37	62/76	60/75	30/37
FC1000-37G4	37/45	76/92	75/90	37/45



# Specification of FC1000

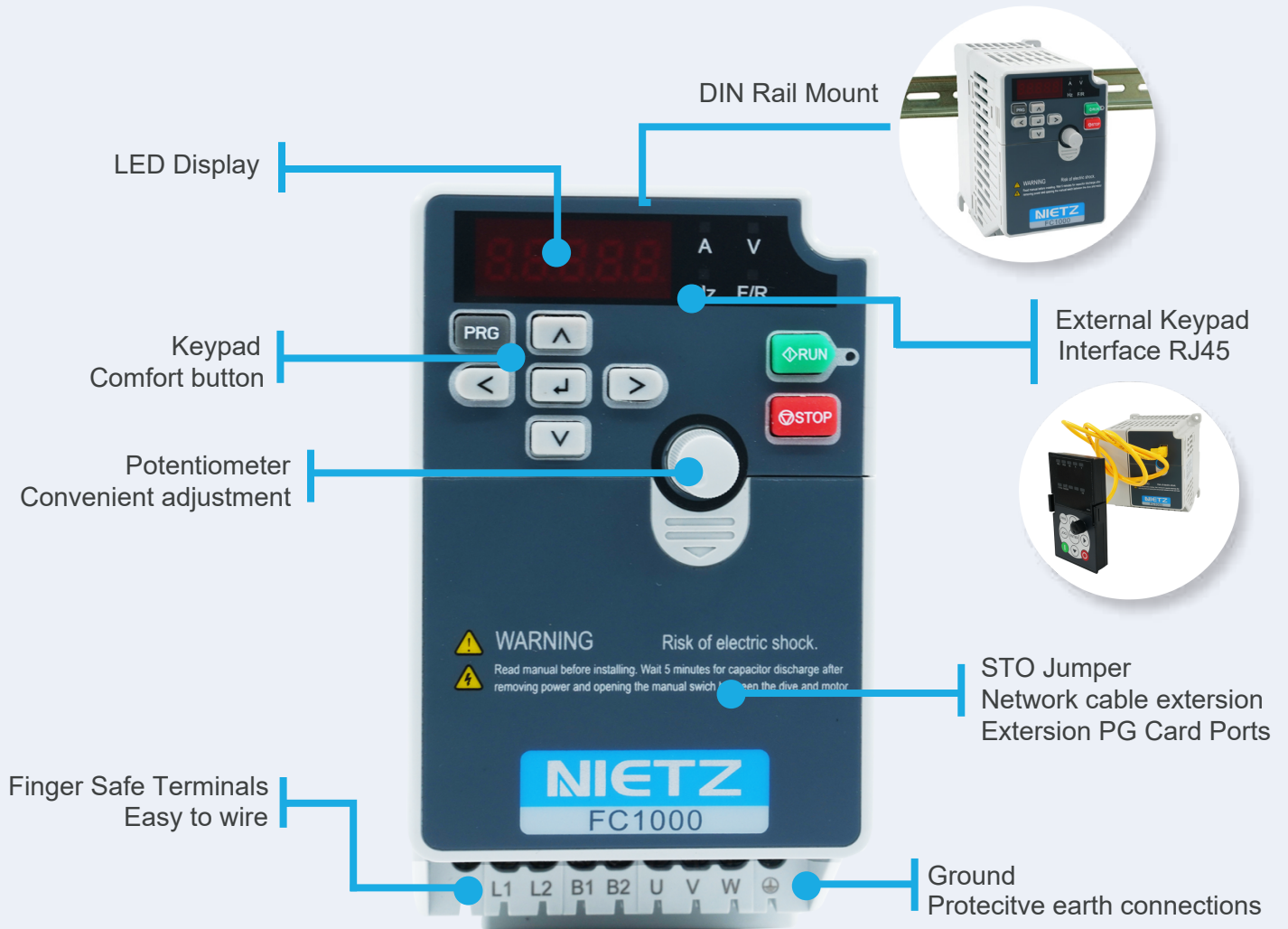

## Dimensions

Model	Overall Dimension, mm				Mount size, mm		Weight kg
	Frame	Hight	Depth	Width	M1	M2	
0.4~1.5kW 220V 0.75~2.2kw 380V without EMC	A	129	129	69	118	56	0.7
2.2kW 220V	B	129	133	109	118	96	0.9
3.7kW 220V	C	185	165	125	175	113	2.0
0.4~3.7kW 380V, with EMC	B	129	133	109	118	96	0.9
5.5~7.5kW 380V	C	185	165	125	175	113	2.0
11~15kW 380V	D	260	165	138	250	126	3.1
18.5~22kW 380V	E	282	174	168	268	152	
30~37kW 380V	F	364	206	205	350	189	
45~55kW 380V	G	420	214.5	262	405	246	

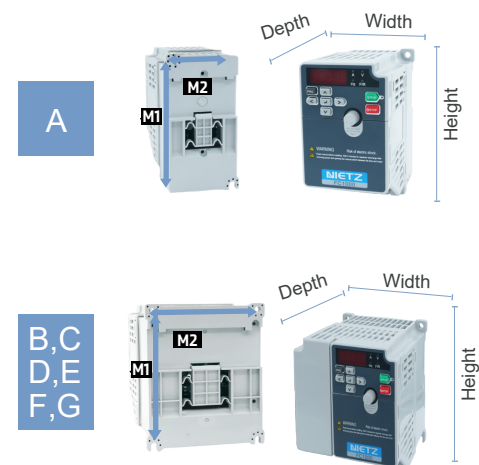

# General Connection Diagram

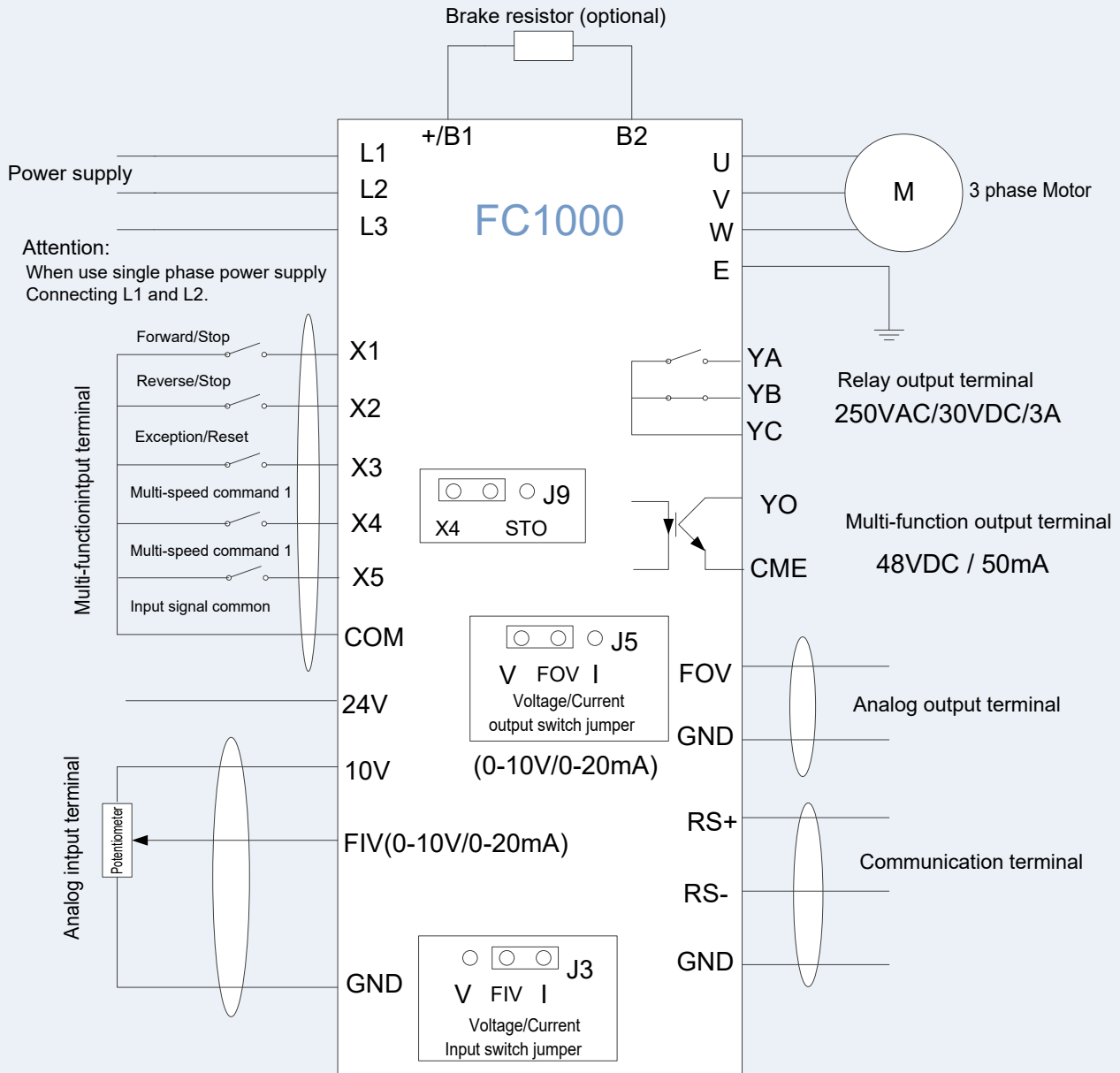

## PC Software tools

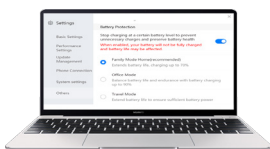

If you are looking to keep a backup copy of parameter set or need to customize the drive's functionality to match your application, the FC1000 has the PC software tools to help.

# Specification of FC1000

Item		Specifications
Basic Function	Control Mode	V/F Control Sensorless Flux Vector Control, SFVC
	Max. Frequency	Vector Control      0.0-599.0 Hz V/F Control            0.0-3200 Hz
	Carrier Frequency	0.5 kHz-16.0 kHz The Carrier Frequency is Automatically Adjusted Based on the Load Features.
	Input Frequency Resolution	Digital Setting      0.01 Hz Analog Setting      Max. Frequency x 0.025%
	Start Torque	G Type                0.5 Hz / 150%, SFVC P Type                0.5 Hz / 100%
	Speed Range	1:100, SFVC
	Speed Stability Accuracy	±0.5%, SFVC
	Overload Capacity	G Type                60s for 150% of the Rated Current, 3s for 180% of the Rated Current. P Type                60s for 120% of the Rated Current, 3s for 150% of the Rated Current.
	Torque Boost	Fixed Boost;            Customized Boost    0.1%~30.0%
	Ramp Mode	Straight-Line Ramp;    S-Curve Ramp Four Groups of Acceleration/Deceleration Time with the Range of 0.00-6500.0s
	DC Braking	DC Braking Frequency    0.00Hz~Maximum frequency Braking Time              0.0s~100.0s Braking Action Current Value 0.0%~100.0%
	JOG control	JOG Frequency Range    0.00 Hz-50.00 Hz JOG Acceleration/Deceleration Time: 0.0s~6500.0s
	Simple PLC, Multiple Preset Speeds	It Implements up to 16 Speeds via the Simple PLC Function or Combination of Terminal States
	Onboard PID	It Realizes Process Controlled Closed Loop Control System Easily
	Auto voltage regulation (AVR)	It Can Keep Constant Output Voltage Automatically when the Mains Voltage Changes
	Overvoltage / Overcurrent Stall Control	The current and voltage are limited automatically during the running process so as to avoid Frequent Tripping Due to Overvoltage/Over Current.
	Rapid Current Limit	It helps to Avoid Frequent Over Current Faults of the AC Drive.
	Torque Limit and Control	It can Limit the Torque Automatically and Prevent Frequent Over Current Tripping During the Runing Process.
	High Performance	Control of Asynchronous Motor are Implemented Through the High-Performance Current Vector Control Technology.
	Running Command Channel	Given by the Panel, Control Terminals, Serial Communication Port, can be Switched by Many Ways.
Frequency Source	There are Ten Frequency Sources. Digital Setting, Analog Voltage Setting, Analog Current Setting, Pulse Setting, Serial Port Setting. You can Perform Switchover Between these Sources in Various Ways.	
Auxiliary Frequency Source	10 kinds of Frequency Source, can be easily realize Micro Adjust, Frequency Synthesizer	
Timing Control	0.0-6500.0 min.	
Communication Methods	RS 485, EtherCAT, Profibus-DP, CAN is optional	
Input & Output	Input Terminal	5 Digital Input Terminals, One of Which Supports up to 100 kHz High-Speed Pulse Input 1 Analog Input Terminals, One of Which Only Supports 0-10V Voltage Input or 4-20mA current input.
	Output Terminal	1 Digital Output Terminal 1 Relay Output Terminal 1 Analog Output Terminal, That Supports 0-20mA Current Output or 0-10V Voltage Output
Others	Protection Function	Motor Shourt-Circuit Detection at Power-On, Output Phase Loss Protection, Over-Current Protection , Overheat Protection and Overload
	Key Locking and Function Selection	It can Lock the Keys Parlially or Completely and Define the Function Range of Some Keys so as to Prevent Mis-Function.
	Protection Class	IP20



## Typical Applications



- Fan, Pumps, Conveyors, Food processing machinery
- Packaging machinery, Textiles, Mixers, Air conditioner
- Water supply System, centrifugal, etc.

## OPTIMIZE MOTOR CONTROL



### NIETZ ELECTRIC CO.,LTD

No.988, Fulian Rd. Gucun  
Industry, Baoshan District.  
Shanghai, China

Tel/Fax: +86 21 336 346 49  
E-mail: [info@nietz.cn](mailto:info@nietz.cn)  
Website: [www.nietz.cn](http://www.nietz.cn)



### DISTRIBUTORS

